

WXF15.800

Lavoce

15" WOOFER

FERRITE MAGNET
ALUMINIUM BASKET DRIVER



- 4 INCH EDGEWOUND CCA VOICE COIL
- 98 dB/SPL SENSITIVITY
- 1600 WATT PROGRAM POWER HANDLING
- FEM OPTIMIZED MOTOR AND SUSPENSIONS
- OPTIMIZED COOLING SYSTEM
- ALUMINIUM DEMODULATING RING
- TRIPLE ROLL SURROUND

GENERAL SPECIFICATIONS

Nominal diameter	mm (in.)	380 (15)
Nominal impedance	Ω	8
Minimum impedance	Ω	6,2
Program power (1)	W	1600
AES Power rating (2)	W	800
Sensitivity (3)	dB	98
Frequency range	Hz	40 ÷ 2000
Voice coil diameter	mm (in.)	100 (4)
Chassis material	Aluminium	
Magnet material	Ferrite	
Magnet dimensions	mm	220 x 110 x 20
OD x ID x h	(in.)	(8.66 x 4.33 x 0.79)
Coil material	Edgewound CCA	
Former material	Glass Fiber	
Cone material	Water Resistant Treated Paper	
Surround material	Polycotton	
Xmax (4)	mm (in.)	7,7 (0.3)
Xmech (5)	mm (in.)	11,7 (0.46)
Gap height	mm (in.)	8 (0.31)
Voice coil winding height	mm (in.)	19,4 (0.76)
Driver displacement volume	l (ft ³)	4,38 (0.154)
Recommended enclosure	l (ft ³)	120 (4.2)
Recommended tuning	Hz	50

SMALL SIGNAL PARAMETERS

DC resistance	Re	Ohm	5,1
Resonance frequency	Fs	Hz	47
Moving mass	Mms	g (oz)	130,6 (4.61)
Compliance	Cms	mm/N	0,087
Force factor	BxL	N/A	22,62
Mechanical Q-factor	Qms		6,14
Electrical Q-factor	Qes		0,39
Total Q-factor	Qts		0,36
Equivalent air volume	Vas	l (ft ³)	90,34 (3.19)
Voice coil Inductance	Le	mH	0,92
Diaphragm area	Sd	cm ² (in. ²)	855 (132.5)
Reference efficiency	Eta 0	%	2,35
Efficiency bandwidth product	EBP	Hz	121

SHIPPING INFORMATION

Net weight	kg (lb.)	10,4 (22.9)
Multipack size (1)	mm	445 x 445 x 195
W x D x H	(in.)	(17.5 x 17.5 x 7.7)
Multipack weight	kg (lb.)	12,8 (28.2)

FREQUENCY RESPONSE AND IMPEDANCE

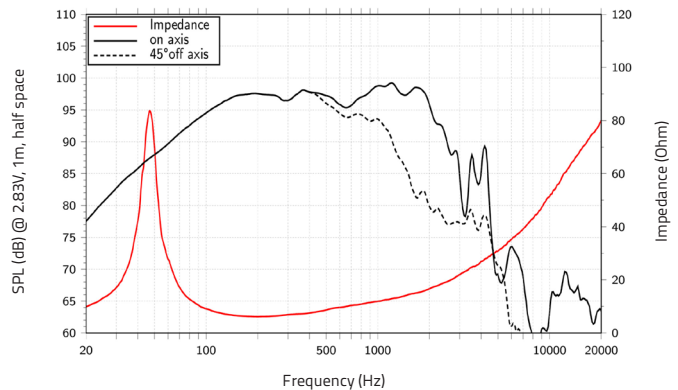

DIMENSIONS mm (in.)

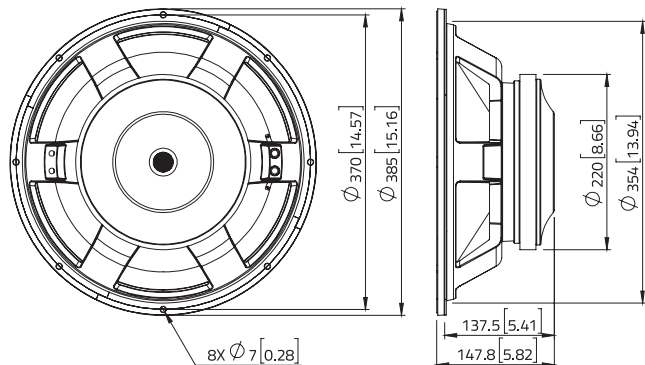

(1) Program power is defined as 3 dB greater than AES Power. (2) Tested for two hours using a continuous, band-limited pink noise signal as per AES 2-1984 Rev. 2003. Loudspeaker tested in free air. (3) From T/S parameters, measured with Klippel DA LPM module. (4) The Xmax is calculated as: $(Hvc - Hg)/2 + Hg/4$. Hvc is the voice coil height and Hg the gap height. (5) The Xmech is calculated as: $(Hvc - Hg)/2 + (Hg - 2)$. Hvc is the voice coil height and Hg the gap height. (6) Thiele-Small parameters are measured after preconditioning: a) at 20°C - 22°C, 50% humidity for 2 hours; b) by Klippel LSI measurement.

All specifications subject to change without notice_H.a

